

Pulsed Flyback Generator

Research Summary - Statistics

This document summarises the research project, explaining the principles of operation, and also the testing for both the Coefficient of Performance and the load tests. It serves to clarify the requirements for appropriate data gathering and processing to best present the evidence.

Over a period of three years a device was built to test the hypothesis: 'That HV or high current intensity pulses, delivered to a battery, can result in a Coefficient of Performance (CoP) greater than 1 and that the whole electrical system can operate in an 'open' manner and harvest energy from the local environment.'

The functional components of the device and the build are laid out in the figure and image below. Based on the principles of devices built by Nikola Tesla, and in recent times by the late John Bedini, the circuit has incorporated various developments but essentially serves to create 'flyback' pulses arising from the interruption of the current in a set of solenoids using either a rotor based switching system or a PWM module with a square wave output.

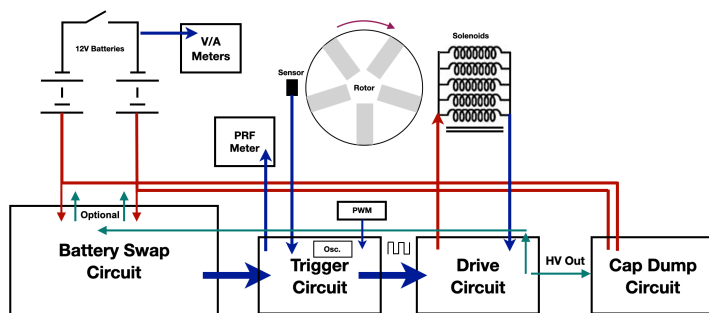

Functional Diagram

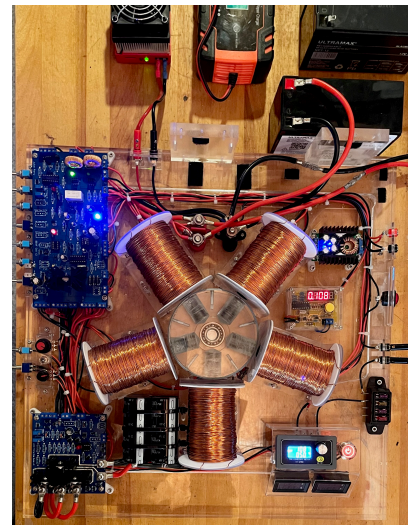

Essential to the system is a battery swapper so that while one battery supplies the energy for the circuit and external load, the other is being pulsed charged. Then, at a suitable interval of typically 15 mins, the batteries swap over their roles. In this way the harvested energy is not applied directly to a load but from the battery storage after pulse charging.

The trigger circuit, using either the rotor/Hall sensor or a PWM module, switches on the main power MOSFET in the drive circuit on the rising edge of the input square wave and off again on the falling edge. At that point the collapsing field in the solenoids results in a high voltage flyback pulse that is seen at the Drain and is routed either directly to the receiving battery or to a capacitor storage system. In that case, at a set threshold voltage, a high current pulse is released from the capacitors to the receiving battery. The reverse

polarity flyback pulses are in the 1-2kV range, depending on the active components fitted, with a FWHM pulse of 20 μ s, ($dV/dt = 1.5E+08$ V/s) and where the limiting factor for the peak HV is not the coils but the 'avalanche rating' of the MOSFET.

Testing the performance of this generator involves a method designed to accommodate the fact that the relative proportions of energy from the transients and the environment is

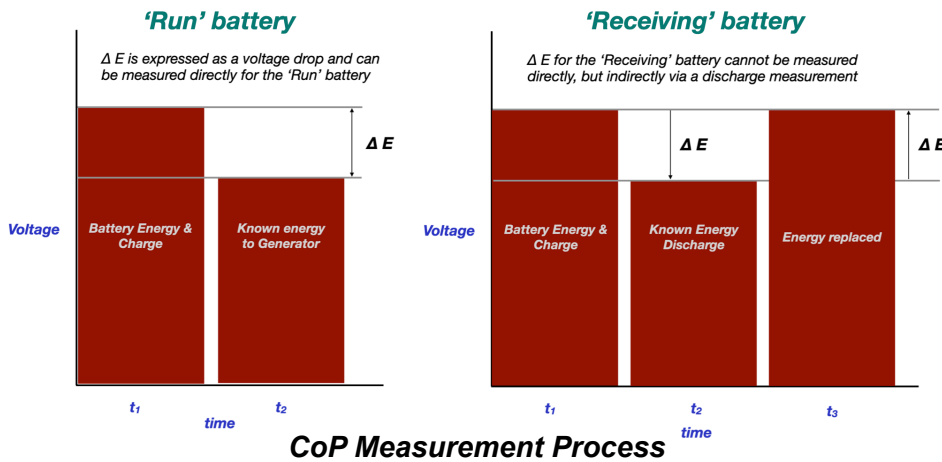

unknown, as indicated in the graphic above, and involves four stages. Firstly, the measurement of a known quantity of energy dissipated through an electronic load from the 'receiving' battery, from a state of full charge.

Secondly, the measurement of the energy delivered by the 'run' battery to the generator in operation. Thirdly, the return of the 'receiving' battery to its original energy state and voltage by the generator in a measured time. Lastly the calculation of CoP as the ratio of 'energy returned to the receiving battery' divided by the 'energy supplied to the generator by the run battery'.

Tests over months have involved the following variables of PRF, duty cycle, coil voltage, swap interval, number of batteries in series, battery capacity and chemistry type. A maximum CoP value of 27.24 ± 0.78 has been obtained so far, although this is only one of the factors determining available external power, the other being the response rate of the battery to the pulses and the time taken to return it to full charge.

Applying HV pulses directly to the battery was found to be more effective than using high current low voltage pulses from the 'cap dump' circuit and so dV/dt appears to be of primary importance for the mechanism of energy influx. Output power tests are in early stages but are indicating levels in the range 60-120W depending on the settings and with more variables to consider and test.

Although the project's primary role is to provide repeatable data for peer review that there is an actual phenomenon of energy harvesting occurring, it is also pertinent to consider the mechanism that is likely involved. The most obvious candidate is vacuum energy resulting from the presence of the HV transients that produce a 'far from equilibrium' state. In such conditions negative entropy may be involved, as in Ilya Prigogine's 'dissipative structures'. Also relevant is the Geometrodynamics of John Archibald Wheeler, who developed aspects of QED involving coherence phenomena of the ZPF in the local space-time metric.

It is a real possibility that short bursts of charged particle influx are occurring with each pulse at the battery electrodes, the interface between the pulses and the battery chemistry.

In an alternative to the Schwinger effect, where a very high field strength can cause direct vacuum polarisation, it has been suggested that a much weaker electric field can interfere with the recombination of pairs of polarised virtual particles and result in a biasing of the energy and charge 'outward' into another system e.g. a battery. It is unclear yet if this project is able to determine if that process is occurring over and above some other option.

Load testing is considered to be essential over and above other practical tests in confirming the proposed harvesting function of a generator of this type. Due to the fact that some factors and variables cannot be fully accounted for or even estimated until a live load is added to the system, and also in this case battery swapping enabled, then accurate measurements of the amount of load that can be sustained can only be done with all the elements of the generator in operation.

Testing the available power output for this type of device can be done using a variation on the so called 'loop' testing procedure. Here, the generator output is fed back into the input such that, if there is more output than is required to run the generator, with its losses, then extra energy is being drawn into the system. In this event the device will continue to run beyond the expectations of its nominal power supply and presents with a $CoP > 1$.

In the Pulsed Flyback Generator, this process in effect occurs every 15mins or so due to the essential battery-swapping mechanism that is integral to its successful operation. Battery swapping is fundamental to the device's operation since there are no known appliances that can run directly off inductive flyback pulses and so storage in a battery or capacitor is an important part of the energy flow.

With the two batteries, at any moment one of them will be the supply or 'run' battery and the other will be the 'receiving' battery. The run battery supplies all the energy for the circuit to operate and also any external load attached to the system, while the receiving battery is being pulsed charged. Then at an interval of typically 15-30mins, the batteries swap over their roles and the now charged 'receiving' battery becomes the 'run' battery.

Given that the energy used by the run battery to charge up the receiving battery is much less than the amount arriving in the receiving battery, for example $1/10$, then there is theoretically $9/10$ th of the energy of the run battery available for an external load and which would equate to a CoP of 9.

Any energy hypothetically drawn in from the 'environment' is first stored in the receiving battery before being used in the next swap cycle for the circuit and load. So in effect, this ongoing process is equivalent to looping the output back into the input but instead of happening in real time, it occurs with a delay equal to the battery swap interval. The energy goes from output to storage, then storage to input with resulting output to storage

etc. and with the receiving battery acting like a giant energy sponge for the harvested energy and charge.

While the CoP measurements involve this looping process, there are also factors and losses that are not easy to quantify and which will be different under load and with no rest time. As such the measurements of the power available from the run battery after a cycle of being charged as the receiving battery, will likely be different from the values predicted from the CoP measurements but which will nevertheless be more realistic and useful.

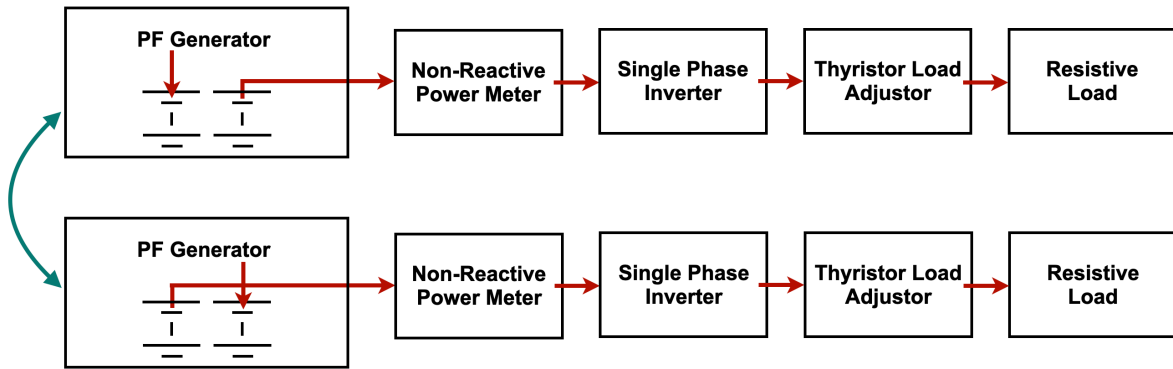

Load testing Setup using AC

The proposed setup shown above consists of a non-reactive power meter connected directly to the generator output so that a reading is taken before any losses resulting from the inverter. The power meter is connected to a single phase inverter whose 50Hz output is then adjusted using a Thyristor unit to feed a series of incandescent lamps. These provide a purely resistive load ranging from 10W to 300W.

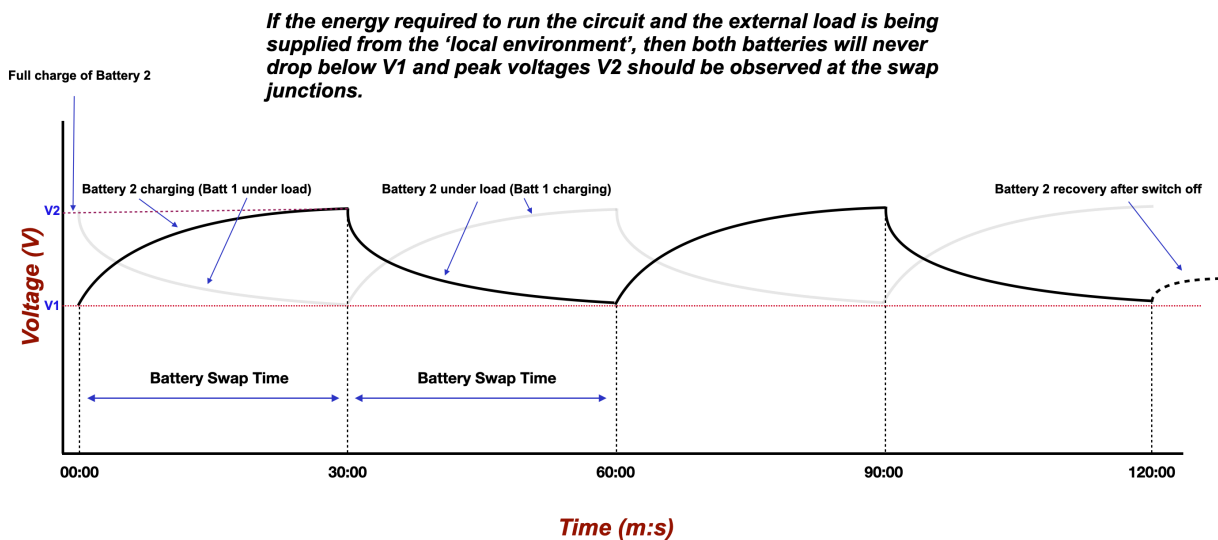

Battery Swapping during Load Testing

Given this, in order to undertake the power measurements, repeated swap cycles are undertaken as shown in the graphic immediately above. At the start of the graph, battery 2 is the receiving battery (black line) and is being pulse charged while battery 1 (the other greyed line) is under load as the 'run' battery while it provides power to both the circuit and the external load.

After 30mins in this case, battery 2 is now at a much higher state of energy and charge and, after the swap, becomes the run battery and battery 1 starts to receive the pulse charging.

If, for example, this swapping cycle continued for 24 hours, there would be 24 complete cycles and 48 swap events. If at the end both batteries have not dropped below V_1 , indicated by the horizontal red dotted line, and equally are still able to reach their peak starting voltages of V_2 , then that is clear evidence that energy has been drawn into the system and that the load is not drawing down more energy than can be replenished during each cycle.

Testing will involve incremental increases to the load to find the point at which a voltage drop is recorded following the recovery phase after a series of cycles. From that value the maximum power output that can be sustained is derived.

At that point, despite the known external load and the dissipation of a measurable amount of energy, the net energy state of the batteries has been maintained through an as yet unspecified process of energy influx.

The relevance of statistics for this research is with regard to the load testing in particular and how much data (in effect the number of test runs) is required to achieve a statistically significant result ($3-4\sigma$?) and how to process the resulting data to best represent the evidence. Also, the issue is pertinent as to whether Numbers for Mac has enough options to manage and present the data to best effect as has been done so far with the CoP measurements.

*Julian Perry MSc, PGCE
3rd November, 2022*

